

Bạc cầu Series E - hoàn toàn bằng thép

Series GE...E (-2RS)

Bạc cầu bằng thép, gia công molybdenum disul-phide mos2, tự bôi trơn

Ứng dụng có tải trọng đa hướng cao

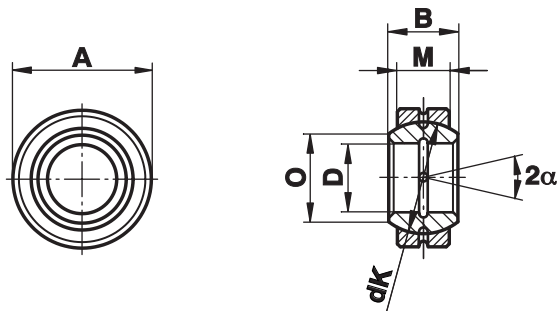

Kích cỡ (D)	B	M	A	O	dK	Tải trọng tĩnh C ₀ kN	Tải trọng động C _k kN	Góc xoay tối đa Angle α (°)	Trọng lượng(g)
4 ¹⁾ _{-0,008}	5	3	12 _{-0,008}	6,0	8,0	10,0	2,0	16	3
5 ¹⁾ _{-0,008}	6	4	14 _{-0,008}	8,0	10,0	17,0	3,4	13	4
6 ¹⁾ _{-0,008}	6	4	14 _{-0,008}	8,0	10,0	17,0	3,4	13	4
8 ¹⁾ _{-0,008}	8	5	16 _{-0,008}	10,2	13,0	27,5	5,5	15	7
10 ¹⁾ _{-0,008}	9	6	19 _{-0,009}	13,2	16,0	40,5	8,1	12	11
12 ¹⁾ _{-0,008}	10	7	22 _{-0,009}	14,9	18,0	54,0	10,8	11	17
15 _{-0,008}	12	9	26 _{-0,009}	18,4	22,0	85,0	17,0	8	26
16 ²⁾ _{-0,008}	14	10	30 _{-0,009}	20,7	25,0	106,0	21,2	10	40
17 _{-0,008}	14	10	30 _{-0,009}	20,7	25,0	106,0	21,2	10	40
20 _{-0,010}	16	12	35 _{-0,011}	24,1	29,0	146,0	30,0	9	64
25 _{-0,010}	20	16	42 _{-0,011}	29,3	35,5	240,0	48,0	7	115
30 _{-0,010}	22	18	47 _{-0,011}	34,2	40,7	310,0	62,0	6	149
35 _{-0,012}	25	20	55 _{-0,013}	39,7	47,0	400,0	80,0	6	228
40 _{-0,012}	28	22	62 _{-0,013}	45,0	53,0	500,0	100,0	7	318
45 _{-0,012}	32	25	68 _{-0,013}	50,7	60,0	640,0	127,0	7	421
50 _{-0,012}	35	28	75 _{-0,013}	55,9	66,0	780,0	156,0	6	562
55 _{-0,015}	40	32	85 _{-0,015}	62,3	74,0	1000,0	200,0	7	864
60 _{-0,015}	44	36	90 _{-0,015}	66,8	80,0	1220,0	245,0	6	1030
70 _{-0,015}	49	40	105 _{-0,015}	77,8	92,0	1560,0	315,0	6	1570
80 _{-0,015}	55	45	120 _{-0,015}	89,4	105,0	2000,0	400,0	6	2320
90 _{-0,020}	60	50	130 _{-0,018}	98,1	115,0	2450,0	490,0	5	2790
100 _{-0,020}	70	55	150 _{-0,018}	109,5	130,0	3050,0	610,0	7	4440
110 _{-0,020}	70	55	160 _{-0,025}	121,2	140,0	3250,0	655,0	6	4830
120 _{-0,020}	85	70	180 _{-0,025}	135,5	160,0	4750,0	950,0	6	8110
140 _{-0,025}	90	70	210 _{-0,030}	155,8	180,0	5400,0	1080,0	7	11200
160 _{-0,025}	105	80	230 _{-0,030}	170,2	200,0	6800,0	1370,0	8	14100
180 _{-0,025}	105	80	260 _{-0,035}	198,9	225,0	7650,0	1530,0	6	18500
200 _{-0,030}	130	100	290 _{-0,035}	213,5	250,0	10600,0	2120,0	7	28400
220 _{-0,030}	135	100	320 _{-0,040}	239,5	275,0	11600,0	2320,0	8	35700
240 _{-0,030}	140	100	340 _{-0,040}	265,3	300,0	12700,0	2550,0	8	39700
260 _{-0,035}	150	110	370 _{-0,040}	288,3	325,0	15300,0	3050,0	7	51500
280 _{-0,035}	155	120	400 _{-0,040}	313,8	350,0	18000,0	3550,0	6	64900
300 _{-0,035}	165	120	430 _{-0,045}	336,7	375,0	19000,0	3800,0	7	77600

Chất liệu:

Lõi: Thép chịu lực 100Cr6, Aisi 52100, cứng, sơn nền, phủ phát hóa, gia công molybdenum disulphide từ kích cỡ 15 có loại có phốt (-2RS) từ kích cỡ 220 chỉ có loại có phốt (-2RS)

Vòng bi: Thép chịu lực 100Cr6, Aisi 52100, cứng, sơn nền, phủ phát hóa, gia công molybdenum disulphide

- 1) không có lỗ bôi trơn
- 2) có loại với đường kính ngoài 28 mm